



QuantaSep® Fusion CC Elite 10000

3 Column Continuous Capture Systems with In-Line Buffer Blending

The QuantaSep Fusion Elite 10000 is a fully integrated Process Chromatography Continuous Capture plus Buffer making skid capable of a flow rate range of 300 ml/min to 10L/min. The product contact flow path is single use and can be easily removed, and a new flow path assembled in less than 1 hour. The system has capabilities of (1) Running chromatography functions on 3 sequential and alternating capture columns in such a way that continuous feed is maintained, (2) Producing Buffers from stock acid and Base concentrated buffer components, Salt and water and (3) Being used in multi-product campaigns by exchanging product contact flow path. The Buffer making functions include enabling use of different recipes of buffers made from a combination of each of the four fluid components.

The Chromatographic functions include loading of Supernatant, Buffer switching, air ejection, conductivity and pH sensing (pre and post column), UV sensing, forward and reverse column and eluate switching between product collection and waste, based on process parameters such as equilibration, loading, washing, elution and regeneration with all columns. The system automatically generates reports of batch history, sensor data and all alarms and events for cGMP reporting. The System is rated for 3 Bar pressure.



The Skid is composed of the fluid handling module and the electronic module integrated into a single unit. The fluid handling module contains all the fluid handling components such as Pumps, valves, sensors and interconnecting pipes. The Control and Electronic module contain the PLC, I/O modules, power supplies, transmitters etc. The floor standing unit is mounted on Plastic casters for easy mobility. The Casters can be locked if needed. The QuantaSep Fusion Elite 10000 is compatible with 1M NaOH and 20% alcohol for CIP operations and is operable at 4°C for cold room processing.

The Industrial computer on which the SCADA based control software resides and controls the Skid via a PLC can be operated from a distance to provide for remote control. The software operates in a MS Windows environment and is 21CFR11 compliant.

- ✓ Continuous Production 24/7 Now!
- ✓ Increase Plant throughput
- ✓ Eliminate Buffer Prep
- ✓ Reduce Space & FTE's
- ✓ Improve Process Economics
- ✓ Increase Resin Utilization
- ✓ No Cleaning Validation
- ✓ Multi-product production with little downtime



The Key Advantage

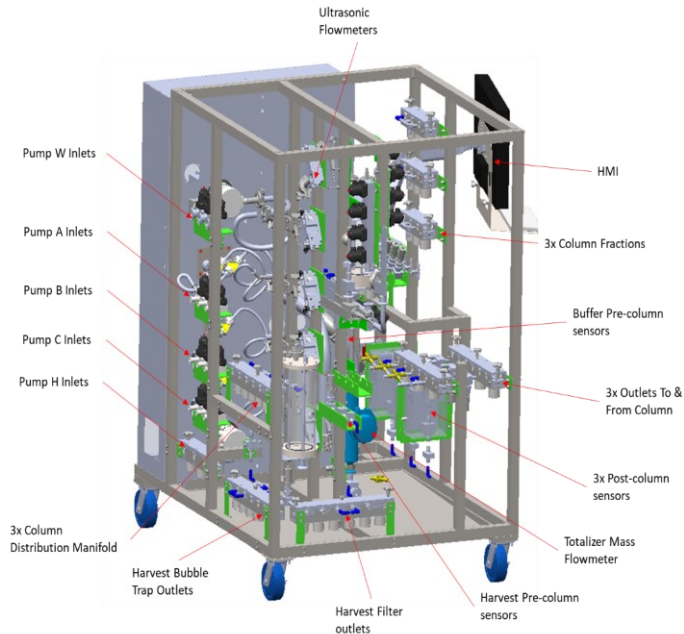

The Tri-column continuous capture:

- 3 Columns with fluid running simultaneously through all three columns sequentially and in parallel. Both Harvest and buffers are running concurrently so loading is happening continuously as are the non-load steps of wash, elution, regeneration and equilibration.
- All columns run the same recipe but are staggered in their operational sequences. The first 2 columns are in "Load" Mode while the 3rd column is in non-load ie. Wash, elution, regeneration followed by equilibration.
- Stock concentrates are used to make in-line buffers used in the chromatographic process.
- Clarified feed is loaded via an exchangeable, flowmeter feedback controlled head diaphragm pump.
- Sensors monitor UV, Conductivity and pH for each column eluent, prior to discharge from skid.
- Eluant Flow is directed to either a product eluant tank or waste.

In Line Buffer Maker

The Buffer maker portion of the system features three inlets each for acid and base concentrated buffer components, water and salt. The Buffer maker makes one buffer at a time. Each of the requisite components has a positive displacement metering pump (Diaphragm, single or multi-piston rotary pump) followed by a flowmeter and are all connected to an in-line manifold consisting of pneumatic valves followed by a static mixer that mixes the fluid components from each of the buffer tanks in-line to provide homogeneous blends. Different buffer compositions are created by running the pumps at different flow rates and blending the resulting flow.

The resultant **Buffer**, is then passes through the pH and conductivity sensors, followed by a Bubble Trap and an **Active Air trap** (air sensor attached to a 3 way valve to expel air from the system and protect the column). The resultant buffer is now distributed into the Chromatographic pathway (either column, fraction collection tanks if so desired, or waste as maybe required by your process).



The QuantaSep® Fusion Elite Software

The Right Combination of Simplicity and Power

The simplicity of the QuantaSep® Fusion Elite interactive graphical user interface gives the system its efficiency and power by making it easy to use and learn. The main screen (Figure 1) displays a flow diagram of the system with all the main components and their real time status quickly and easily. By simply clicking the mouse, you can open or close a valve, stop or start a pump, set new flow rates, collect fractions and perform other system operations all from your work station.

Intuitive Protocol Design

Programming is simple. Open the method editor by clicking on the icon on the tool bar. Then key in steps in the table, stepping through different buffers and changing buffer or fraction steps based on UV, conductivity, pH or air. Simply click on the gradient box and choose your gradient profile. Click on the event box and zero the UV baseline before you load your product or program in a pause before you start eluting your product!

Security

The multi-levels of password protection restrict access to the system. For instance, an operator may have provision to run a method but not change the parameters; only the supervisor may be given that responsibility. In another instance, only the QA or metrology group may have access to setting calibration parameters. The security administrator in the software can enable all this and more.

CGMP Documentation and Data Analysis

All events manual or automatic (including deviations) are recorded to the batch log. Reports consisting of the method, buffers used, all alarms and events, chromatogram data and analysis can be printed or archived as part of the batch log. The Instant Data

Analysis helps do a quick check of an ongoing process against baseline data hence preventing possible losses.

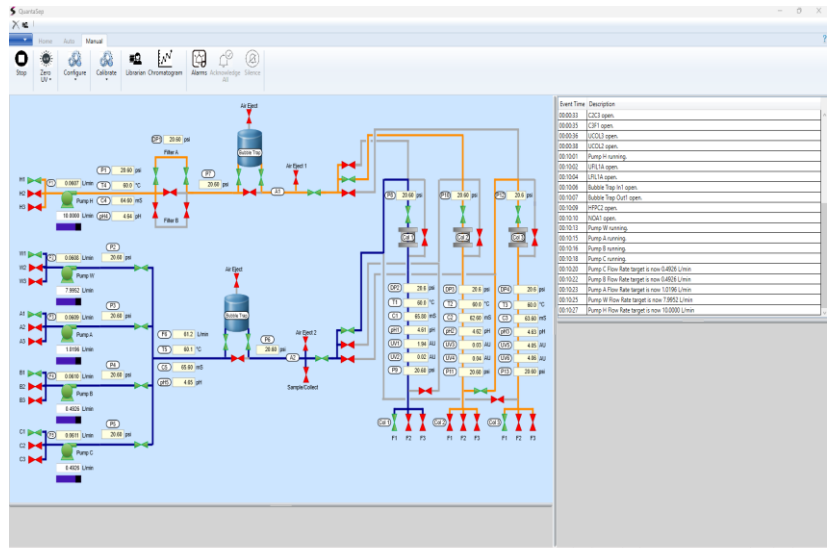

Figure 2

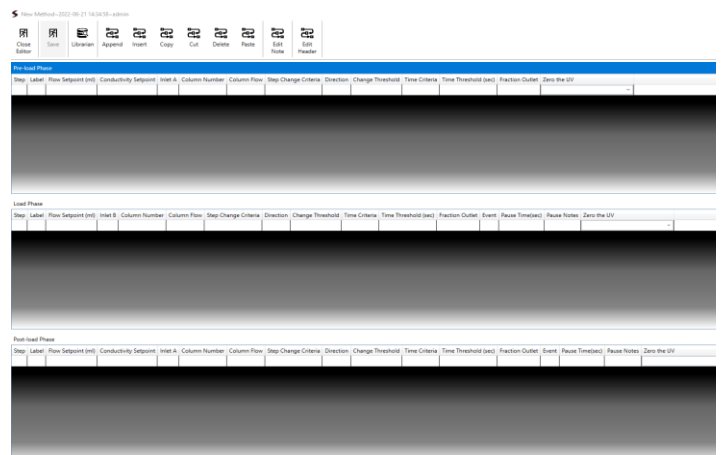

Figure 3

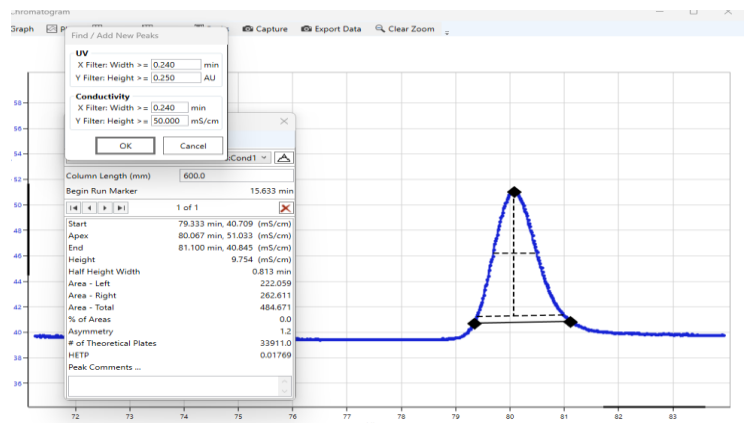

Figure 4

QuantaSep® Fusion Elite 10000 Has What It Takes

General

- Automates buffer making, column switching, fraction collection, based on UV, pH and conductivity.
- Compact mobile system can fit in a small pilot plant or cold room.
- Graphical, intuitive software “dashboard” for easy operation and training.
- Automation and Control
 - PLC, Digital & Analog I/O & PC driven SCADA software
- Automated GMP reports
 - Complete batch reports
 - Method, Event and alarm logs
 - Chromatograms logged to disk
 - Calibration history
 - All trends stored once every second
 - Data Archival and Security
- Sensors
 - 3 **UV** detectors, one at egress of each column
280nm, 260nm
Path length: 0.5 cm standard
Range: 0-4.0 AU/0,5 cm
Accuracy: $\leq 0.1\text{AU} \pm 0.01\text{AU} \pm 5\%$ Reading;
Linearity: $\pm 5\%$
 - 5, **Conductivity** - 1x for buffer, 1x for feed line and 1x after each column
Range: 0.1 – 200mS $\pm 2\text{mS}$ and ability to read in μS
 - 5 **pH** - Buffer, Feed and after each column
Range: 1 – 14 $\pm 0.1\text{pH}$
 - **Pressure** – 13 (5x Buffer Line, 8X Feed line)
 - **Temperature** – 4 – 40° C
 - **Air** – 2 (one for Buffer and one for feed line)
 - **Leak**
 - 2 L Bubble Trap – 2 (1x Single use on Feed line & 1x Multi use on Buffer Line with Automatic Level detection and control)

Physical

Mobile Unit on Castors with brakes
48” deep by 60” wide by 72” tall

Warranty, Installation & Support

All QuantaSep® Fusion Elite systems are backed by Sepragen’s one year limited warranty. Installation and training, along with IQ/OQ are performed by the Sepragen Service Group. Preventive maintenance services are provided at additional cost



33470 WESTERN AVE, UNION CITY, CA 945487
PHONE: 510-475-0650 FAX: 510-440-5395
HTTP://WWW.SEPRAGEN.COM

General

Pump W -	0.17 – 10L/m Diaphragm Pump
Pump A -	0.04 – 2 L/m Multi-Piston Pump
Pump B -	0.02 – 1 L/m Piston Pump
Pump C -	0.02 – 1 L/m Piston Pump
Pump H -	0.17 – 10 L/m Diaphragm Pump (Exchangeable pump head)
Pump Mixing	
Turn-down -	30:1 (low end 30ml/min)
Valves -	Pneumatic Pinch (Feed)
Valves -	Pneumatic Pinch (Column)
Valves -	Pneumatic diaphragm (Buffers)
Valves -	Pneumatic diaphragm (Fractions)
Flow Meter -	6
	1x Mass Flowmeter <600 ml $\pm 50\text{ml}$; >600ml & 3.3lpm $\pm 1\%$ reading; >3.3 lpm $\pm 0.1\%$ reading
	5x Ultrasonic Flowmeter 0 – 10 LPM (<1 LP: $\pm 10\text{ml/min}$; >1LPM: $\pm 1\%$ Reading)
	0 – 2 LPM (<0.3 LP: $\pm 3.3\text{ml/min}$; >0.3LPM: $\pm 1\%$ Reading)
	0 – 1 LPM (<0.3 LP: $\pm 3.3\text{ml/min}$; >0.3LPM: $\pm 1\%$ Reading)

3 Column Manifold

In from feed or previous column/ forward to next column and flow through to collection

System Volume ~2.5L (Excluding Bubble Trap)
System Pressure 50 psi
Tube Size - $\frac{1}{4}$ ” and $\frac{1}{2}$ - $\frac{3}{4}$ ” I.D.
Connection - Sanitary Tri-Clamps

Surface Finish

SS wetted 0.8 μm

Materials of Construction (Wetted Parts)

HDPE, P.P., PTFE, Platinum cured or reinforced
Silicone (USP Grade VI, ADI Free), Ceramic,
Quartz, Platinum and EPDM

Chemical Compatibility

1M Sodium Hydroxide, 19% Alcohol
Operating Temp 4°C - 25°C

Utilities Requirement

Power Requirement 30A @ 220 VAC
@ 50-60 Hz
Air Requirement Instrument quality
Regulated air at 50psi

To learn more call:

(510) 475-0650

E-mail: info@sepragen.com