



QuantaSep® Adept 300

Bench-Scale Automated Chromatography System with Single-Use Flow Path for Clinical Production

The QuantaSep® Adept 300 is a **Single Use** Automated benchtop/compact Chromatography System, capable of providing an operating flow range of 10-100ml/min or 30-300 ml/min depending on flow path chosen. The integrated system has dual computer controlled pumps, up to 12 buffer selection valves, an inline mixer, filters, and 6 fraction collection valves. Its capabilities include but are not limited to buffer switching, gradient formation, feed pre-filtering, air ejection, conductivity and pH sensing pre- and post-column, and forward and reverse flow in a powerful easy-to-use software package. The software enables buffer and fraction switching based on process conditions and activates alarms in the event of overpressure, or air leaks. All events are automatically logged and



The QuantaSep® Adept 300 hardware is composed of control modules and a fluid handling combined into a single ergonomically designed counter high cabinet. The bench top unit can be cart-mounted for easy mobility. The computer that houses the control software can be integrated with or separated from the system to provide the option of remote operation. The system is compatible with 1M NaOH and alcohol for CIP operations and is operable at 4°C for cold room processing.

- ✓ No Cleaning Validation
- ✓ Step & Linear Gradients
- ✓ Reduce Batch Failures by Fail Safe System
- ✓ Unattended Clinical Production 24/7 Now!
- ✓ Capable of Dual Flow Range; 10-100 ml/min or 30-300 ml/min
- ✓ Use Safely on Multiple Products
- ✓ Generate Automated cGMP Reports
- ✓ Improve Product Quality & Reliability



The QuantaSep® Adept 300

QuantaSep® Hardware

The fluid handling module contains: 2 pump assemblies consisting of two peristaltic pumps, static mixer, and silicone tubing. These are connected with sanitary clamp connections to pinch valves, UV, pH, leak, conductivity, temperature and pressure sensors, air sensor, air purge valve, sanitary inlets, outlets, and column connections. The components are mounted inside an enclosed stainless steel cabinet with a trough to which a leak detector is attached.

Removable Flowpath

The flowpath of this system is designed for easy removal. This eliminates the need for cleaning validation. Issues related to cross-contamination in switching columns or products are substantially minimized when the flowpath can simply be replaced. Pinch valves and peristaltic pumps enable easy changing of the pre-fabricated tubing assembly along with the integrated sensor block, which can be easily removed and replaced as well.

Controls Module

The controls module contains all power supplies, transformers, valve activation pneumatics, brainboards, sensor controls and circuit boards, alarm controls, sensor electronics including A/D and D/A converters and fuse assembly. The status LED's, an emergency stop switch, cables, computer interface, fuse blocks, etc. are included as well.

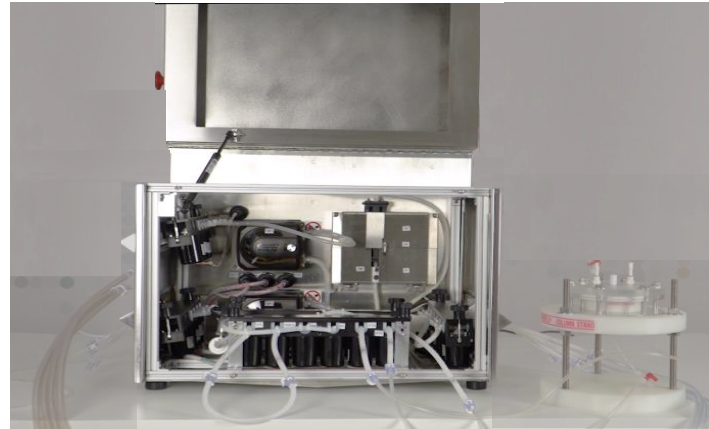

The QuantaSep® Hardware:

- (A) **Up to 6 selectable buffer ports per pump for total of 12** - Manifold of six pneumatically actuated diaphragm valves on each pump to provide flexibility.
- (B) **Two precision positive displacement pumps** - Each at 10-100 ml/min or 30-300 ml/min are used to allow one to purify small and large amounts using the same unit.
- (C) 1) **Inline ΔP sensors** - The discharge of both pumps is manifolded together to a static mixer for effective gradient formation.
2) **Inline pre-filtering capability** - A manifold of sanitary valves with ΔP sensors enables the attachment of a pre-filter for debris or particular removal pre-column.
- (D) **Optional pH and conductivity sensors** - Can monitor pre-column pH and conductivity of buffers or load material. This helps prevent loading of wrong buffers and hence loss of product.
- (E) **Auto air eject** - An "active air trap" consisting of an air sensor and three-way air ejection valve continuously detects and removes unwanted air before the column thus preventing loss of raw material and valuable production time.
- (F) **Column forward/reverse capability** - The flow is directed to the column through a valve manifold, which can route flow to the column in a forward, reverse or bypass mode for flexibility in your product.
- (G) **Post column sensors** - Consist of a single flow cell capable of UV dual-wavelength (280 and 254 nm) detection and pH and conductivity detection. Minimize hold up volume of sensor lag time.
- (H) **6 user selectable fraction ports** - Fractions can be collected via a manifold comprising of 6 pneumatically actuated valves.

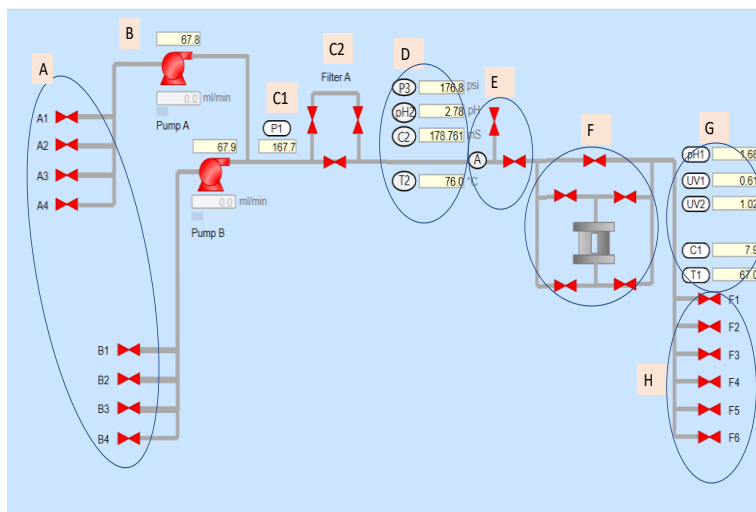
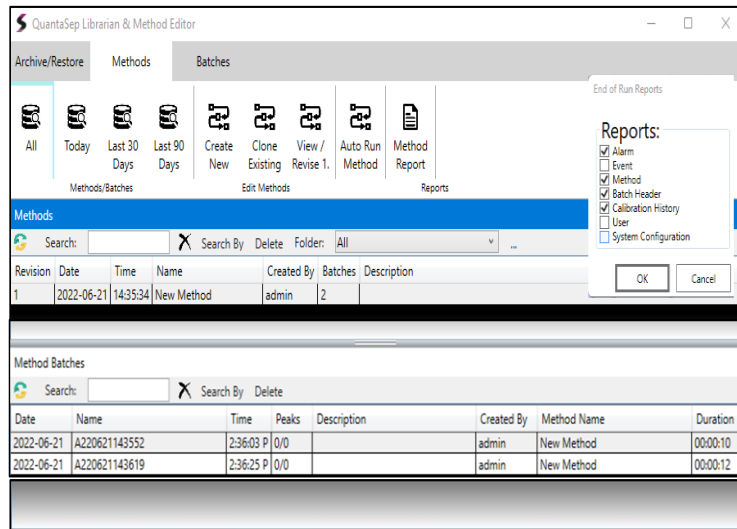

Figure 1

The QuantaSep® Software

The Right Combination of Simplicity and Power

The simplicity of the QuantaSep® Adept interactive graphical user interface gives the system its efficiency and power by making it easy to use and learn. The main screen (Figure 1) displays a flow diagram of the system with all the main components and their real time status quickly and easily. By simply clicking the mouse, you can open or close a valve, stop or start a pump, set new flow rates, collect fractions and perform other system operations all from your workstation.



Intuitive Protocol Design

Programming is simple. Open the method editor by clicking on the icon on the tool bar. Then key in steps in the table, stepping through different buffers and changing buffer or fraction steps based on UV, conductivity, pH or air. Simply click on the gradient box and choose your gradient profile. Click on the event box and zero the UV baseline before you load your product or program in a pause before you start eluting your product!

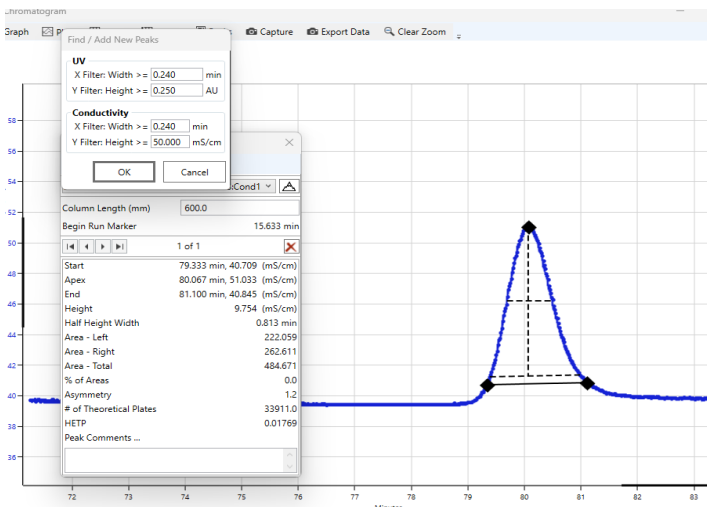

Security

The multi-levels of password protection restrict access to the system. For instance, an operator may have provision to run a method but not change the parameters; only the supervisor may be given that responsibility. In another instance, only the QA or metrology group may have access to setting calibration parameters. The security administrator in the software can enable all this and more.

cGMP Documentation and Data Analysis

All events manual or automatic (including deviations) are recorded to the batch log. Reports consisting of the method, buffers used, all alarms and events, chromatogram data and analysis can be printed or archived as part of the batch log. The Instant Data Analysis helps do a quick check of an ongoing process against baseline data hence preventing possible losses.

Event Time	Description
00:00:01	Manual Mode running.
00:00:05	F9 open.
00:00:11	UCREV3 open.
00:00:11	LCREV3 open.
00:00:17	A2 open.
00:00:31	Pump A Flow Rate target is now 770.0 ml/min
00:00:34	Pump A running.
00:00:39	B3 open.
00:00:45	Pump B Flow Rate target is now 434.0 ml/min
00:00:47	Pump B running.

QuantaSep® Adept 300 Features

Pre-sterilized Removable Flow Path



- Low system volume
- Minimal dead legs
- Up to 6 inlet quick disconnect buffer selection connections per pump (total of 12)
- Six fraction quick disconnect Fraction selection connections
- Conductivity flow cell
- UV flow cell
- PH sensor
- Temperature sensor
- Peristaltic pump tubing
- Mixer
- Pressure sensor
- Optional Flow Sensors

General

- Automates buffer delivery, column switching, fraction collection, based on UV, pH and conductivity.
- Compact mobile system can fit in a small pilot plant or cold room.
- Graphical, intuitive software “dashboard” for easy operation and training.
- Automated GMP reports
 - Complete batch reports
 - Event and alarm logs
 - Chromatograms and calibration history
 - Data Archival and Security
- Precision Hardware
 - Pinch valves
 - High pressure peristaltic pumps
 - Large dynamic flow range
 - 30:1 turndown ratio for accurate gradients
- Sensors
 - Optional Ultrasonic Flow Sensor
 - UV, pH and conductivity sensors
 - Optional pre-column pH and conductivity sensors
 - Optional second 254 nm UV capability
 - Pressure, temperature, air, leak
- Safety features
 - “Active air trap” minimizes “bubble trap dilution”
 - Optional pre-column filter with differential pressure sensors
 - Leak and pressure alarms
 - Built-in safety interlocks
 - Software method checks
 - Software security prevents unauthorized operation and tampering of data

QuantaSep® Adept 300 Specs

General

Gradients	10-90% of ratio $\pm 5\%$
Valves	Tubing pinch valves
System Hold up Volume	20 ml
System Pressure	50 psi
Air Bubble Eject Size	> 1 mm
2 pumps	Peristaltic Pumps
1.6 mm tubing	10-100 ml/min $\pm 3\%$
3.2 mm tubing	30-300 ml/min $\pm 3\%$
UV Sensor (280 nm)	Range 0-2 Au;
Optional (254 nm)	Path length 1.0 cm
	Accuracy ± 0.1 Au
Conductivity Sensor	Range 0-200 ms;
	Accuracy $\pm 5\%$ F.S.
pH Sensor	Range 1-14;
	Accuracy ± 0.2 pH
Pressure Sensor	Range 0-100 psi;
	Accuracy ± 1.0 psi
Ultrasonic Flow Sensor	0-300 ml/min, $\pm 0.5\%$
Inlet Buffer Selection	6 per pump
Fraction Selection	6
Column	1 Fwd, Reverse & Bypass
Pre-filter	1

Flow Path

Flow paths are pre-assembled with sensors and shipped sterile

All wetted materials are USP Grade VI, ADI-Free

Materials, Flow cell	Quartz / Polypropylene
Fitting Mixer	Polypropylene/HDPE
Valve Reinforced Silicone	
Tubing	Silicone (Reinforced)
Gaskets	Silicone
pH Electrodes	Glass
Pump Tubing	Stapure or Bioprene
UV Flow Cell Window	Quartz
Pressure/Temp Sensors	316L Stainless Steel

Chemical Compatibility

1M Sodium Hydroxide, 19% Alcohol	
Operating Temp	4°C - 37°C

Utilities Requirement

Power Requirement	110/220V; 6Å
-------------------	--------------

Physical

30" wide x 24" deep x 26.5" tall

To learn more call: (510) 475-0650

E-mail: info@sepragen.com