



QuantaSep® Adept Premier 10000

Pilot-Scale Automated Chromatography System with **Single-Use Flow Path** with In-line Buffer Dilution

The QuantaSep® Adept Premier 10000 is a **Single Use** compact Automated Chromatography systems which is capable of providing a dual operating flow range of 50ml/ min to 5L/min or 100ml/min to 10L/min depending on the flow path chosen. The integrated system has two computer controlled pumps, 8 buffer selection valves, an inline mixer, filters, and 6 fraction collection valves. Its capabilities include but are not limited to buffer switching, gradient formation, feed pre-filtering, air sensing and ejection, conductivity and pH & UV sensing and fraction collection, and **In line Buffer dilution** in a powerful easy-to-use software package. The software enables buffer and fraction switching based on process conditions and in-line dilution to target conductivity and activates alarms in the event of overpressure, or air leaks. All events and alarms are automatically logged and available as a run report.



Flow Rate: 50mls / min to 5 L / min
100mls / min to 10 L/min

The QuantaSep® Adept Premier 10000 hardware is composed of control modules and a fluid handling combined into a single ergonomically designed open skid architecture for easy flow path exchange and mobility. The industrial computer that houses the control software can be integrated with or separated from the system to provide the option of remote operation. The system is compatible with 1M NaOH and alcohol for CIP operations and is operable at 4°C for cold room processing.

- ✓ In-line Buffer Dilution
- ✓ Step & Linear Gradients
- ✓ No Cleaning Validation
- ✓ Easy to Replace Presterilized flow paths with disposable sensors and tubing
- ✓ Use Safely on Multiple Products
- ✓ Capable of Dual Flow Range: 250ml/min to 5 L/min or 500ml/min to 10L/min
- ✓ Generate Automated cGMP Reports
- ✓ Unattended Clinical Production 24/7 Now!



The QuantaSep® Adept Premier 10000

QuantaSep® Hardware

The QuantaSep Adept Primer 10000 fluid handling module contains: 2 pump assemblies consisting of two pumps, static mixer, and silicone tubing. These are connected with sanitary clamp connections to pinch valves, UV, pH, leak, conductivity, temperature and pressure sensors, air sensor, air purge valve, sanitary inlets, outlets, and column connections. The components are mounted inside an enclosed stainless steel cabinet with a trough to which a leak detector is attached.

Removable Flowpath

The flowpath of this system is designed for easy removal. This eliminates the need for cleaning validation. Issues related to cross-contamination in switching columns or products are substantially minimized when the flowpath can simply be replaced. Pinch valves and peristaltic pumps enable easy changing of the pre-fabricated tubing assembly along with the integrated sensor block, which can be easily removed and replaced as well.

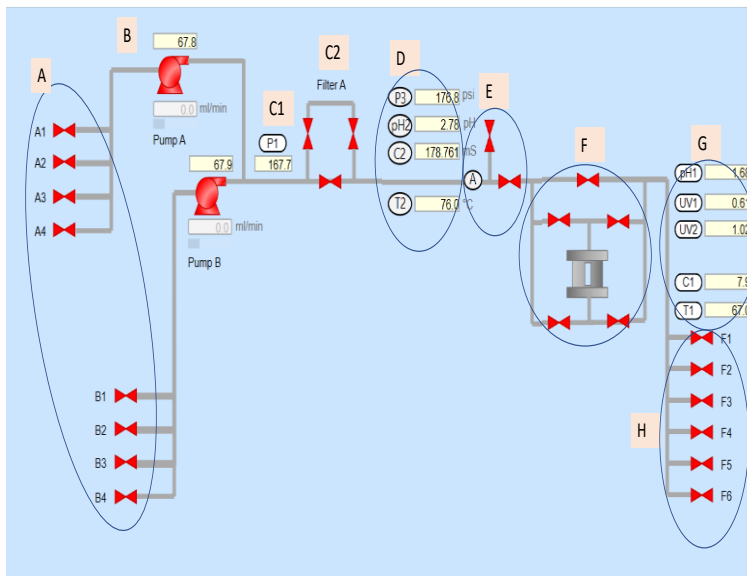
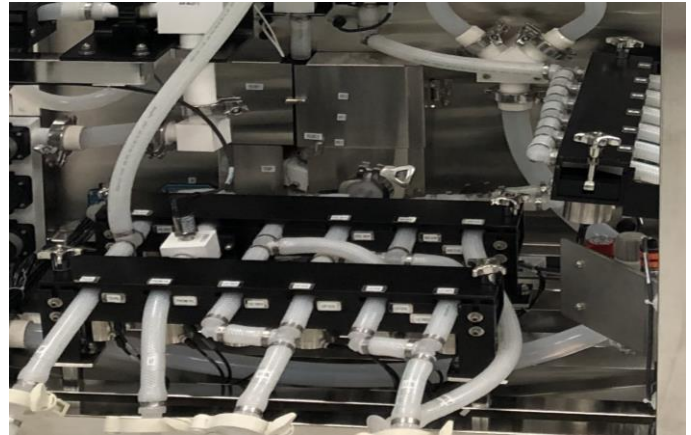

Figure 1

Controls Module

The controls module contains all power supplies, transformers, valve activation pneumatics, brainboards, sensor controls and circuit boards, alarm controls, sensor electronics including A/D and D/A converters and fuse assembly. The external chart recorder interface, status LED's, an emergency stop switch, cables, computer interface, fuse blocks, etc. are included as well.

The QuantaSep® Hardware:

- (A) **4 selectable buffer ports** - Manifold of four pneumatically actuated diaphragm valves on each pump to provide flexibility.
- (B) **Two precision positive displacement pumps** - Each of the two ranges at 50 to 5000 ml/min and 500ml to 10L/min are used to allow one to purify small and large amounts using the same unit.
- (C) 1) **Inline ΔP sensors** - The discharge of both pumps is manifolded together to a static mixer for effective gradient formation.
2) **Inline pre-filtering capability** - A manifold of sanitary valves with ΔP sensors enables the attachment of a pre-filter for debris or particulate removal pre-column.
- (D) **Pre Column pH and conductivity sensors** - Can monitor pre-column pH and conductivity and dilute buffers to the desired conductivity. Prevent loading of wrong buffers and hence loss of product.
- (E) **Auto air eject** - An "active air trap" consisting of an air sensor and three-way air ejection valve continuously detects and removes unwanted air before the column thus preventing loss of raw material and valuable production time.
- (F) **Column forward/reverse capability** - The flow is directed to the column through a valve manifold, which can route flow to the column in a forward, reverse or bypass mode for flexibility in your product.
- (G) **Post column sensors** - Consist of a single flow cell capable of UV dual-wavelength (280 and 254 nm) detection and pH and conductivity detection. Minimize hold up volume of sensor lag time.
- (H) **6 user selectable fraction ports** - Fractions can be collected via a manifold comprising of 6 pneumatically actuated valves.

The QuantaSep® Software

The Right Combination of Simplicity and Power

The simplicity of the QuantaSep® interactive graphical user interface gives the system its efficiency and power by making it easy to use and learn. The main screen (*Figure 1*) displays a flow diagram of the system with all the main components and their real time status quickly and easily. By simply clicking the mouse, you can open or close a valve, stop or start a pump, set new flow rates, collect fractions and perform other system operations all from your work station.

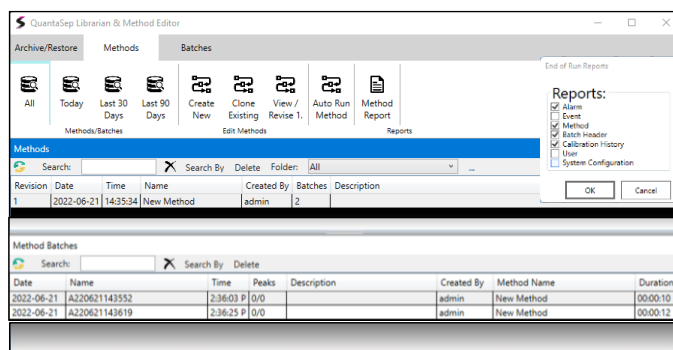

Intuitive Protocol Design

Programming is simple. Open the method editor by clicking on the icon on the tool bar. Then key in steps in the table, stepping through different buffers and changing buffer or fraction steps based on UV, conductivity, pH or air. Simply click on the gradient box and choose your gradient profile. Click on the event box and zero the UV baseline before you load your product or program in a pause before you start eluting your product!

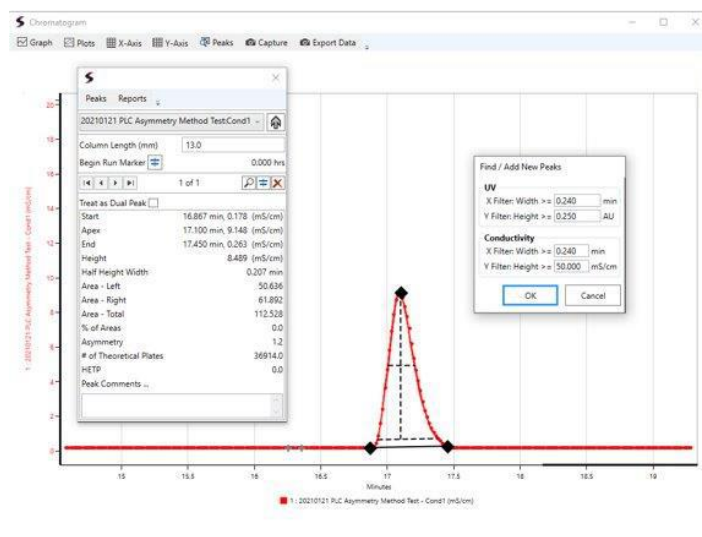

Security

The multi-levels of password protection restrict access to the system. For instance, an operator may have provision to run a method but not change the parameters; only the supervisor may be given that responsibility. In another instance, only the QA or metrology group may have access to setting calibration parameters. The security administrator in the software can enable all this and more.

CGMP Documentation and Data Analysis

All events manual or automatic (including deviations) are recorded to the batch log. Reports consisting of the method, buffers used, all alarms and events, chromatogram data and analysis can be printed or archived as part of the batch log. The Instant Data Analysis helps do a quick check of an ongoing process against baseline data hence preventing possible losses.

Event Time	Description
00:00:01	Manual Mode running.
00:00:05	F9 open.
00:00:11	UCREV3 open.
00:00:11	LCREV3 open.
00:00:17	A2 open.
00:00:31	Pump A Flow Rate target is now 770.0 ml/min
00:00:34	Pump A running.
00:00:39	B3 open.
00:00:45	Pump B Flow Rate target is now 434.0 ml/min
00:00:47	Pump B running.

QuantaSep® Adept Premier 10000 Features

Pre-sterilized Removable Flow Path

- Low system volume
- Minimal dead legs
- Six each inlet quick disconnect buffer selection and Fraction selection connections
- Conductivity flow cell
- UV flow cell
- PH sensor
- Temperature sensor
- Reinforced Silicon tubing
- Mixer
- Pressure sensor

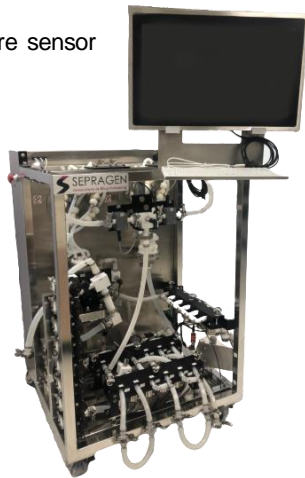

General

- Automates buffer delivery, column switching, fraction collection, based on UV, pH and conductivity.
- Compact mobile system can fit in a small pilot plant or cold room.
- Graphical, intuitive software “dashboard” for easy operation and training.
- Automated GMP reports
 - Complete batch reports
 - Event and alarm logs
 - Chromatograms and calibration history
 - Data Archival and Security
- Precision Hardware
 - Pinch valves
 - Disposable Diaphragm / Rotary Piston Pumps
 - Large dynamic flow range
 - 20:1 turndown ratio for accurate gradients
- Sensors
 - UV, pH and conductivity sensors
 - Optional pre-column pH and conductivity sensors
 - Optional second 254 nm UV capability
 - Pressure, temperature, air, leak
- Safety features
 - “Active air trap” minimizes “bubble trap dilution”
 - Optional pre-column filter with differential pressure sensors
 - Leak and pressure alarms
 - Built-in safety interlocks
 - Software method checks
 - Software security prevents unauthorized operation and tampering of data (21 CFR Pt 11 Compliance)



33470 WESTERN AVE, UNION CITY, CA 94587
PHONE: 510-475-0650 FAX: 510-440-5395
HTTP://WWW.SEPRAGEN.COM

QuantaSep® Adept Premier 10000 Specs

General

2 pumps	-Diaphragm Rotary Piston Pumps
9.6 mm tubing	250 ml/min - 5 L/min $\pm 3\%$
12.5 mm tubing	500 ml/min – 10 L/min $\pm 3\%$
Gradients	10 - 90% of ratio $\pm 5\%$
Valves	Tubing pinch valves
System Volume	1 Liter
System Pressure	50 psi
Air Bubble Eject Size	>1 mm
UV Sensor (280 nm)	Range 0-4 Au;
Optional (254 nm)	Path length 0.5 cm Accuracy ± 0.1 Au
Conductivity Sensor	Range 0.1 - 200 ms; Accuracy $\pm 5\%$ F.S.
pH Sensor	Range 1-14; Accuracy ± 0.2
Pressure Sensor	Range 0-100 psi; Accuracy ± 1.0 psi
Ultrasonic Flow Sensor	250ml/min – 10 L/min $\pm 2\%$
Inlet Buffer Selection	Up to 6 per pump
Fraction Selection	6
Column flow direction	1 Fwd, Reverse & Bypass
Pre-filter	1

Flow Path Materials

Manifolds, Flow cell,	
Fitting Mixer	Polypropylene
Valve Reinforced	Silicone
Tubing	Silicone
Gaskets	Silicone
pH Electrodes	Glass
Pump Tubing	Reinforced Silicone
UV Flow Cell Window	Quartz
Pressure/Temp Sensors	316L Stainless Steel
<i>All wetter materials are USP Grade VI</i>	

Chemical Compatibility

1M Sodium Hydroxide, 19% Alcohol	
Operating Temp	4°C - 40°C

Utilities Requirement

Power Requirement	110/220V; 15Å
-------------------	---------------

Physical

36" wide x 30" deep x 48" tall

To learn more call:

(510) 475-0650

E-mail: info@sepragen.com