

SONY

FP7000

Spectral Cell Sorter



Sony Biotechnology Inc.

Delivering High-Parameter Cytometry Solutions Powered by Innovative Design and Reliability

A high-end sorter from the pioneer of spectral cytometry

The newest addition to our spectral cytometry portfolio is the FP7000, a high-speed spectral cell sorter.

Sony introduced the world's first commercially available spectral cytometer in 2012 and paved the way for the use of this technology in the mainstream life sciences community. In recent years, spectral cytometry has transitioned from an emerging technology to an essential tool.

It enables scientists to glean in-depth information on a per-cell basis, phenotype rare cell subsets, and generate high-parameter data more easily with the choices of fluorochromes available to them.

With the adoption of spectral cytometry across academic laboratories, shared research facilities, and biopharma, Sony has recognized the need for delivering spectral instrumentation that is both reliable, easy to use and accessible. Over the past decade, Sony's spectral cell analyzers have enabled researchers to use a wider variety of fluorochrome combinations than previously possible with traditional systems.

The latest system in our spectral portfolio has innovative technologies to offer the flexibility needed for a wide range of sorting applications, without compromising the reliability, usability, and intelligent automation that has been the hallmark of the Sony Biotechnology family of products.

Designed with state-of-the-art spectral optics matched with the ID7000™ Spectral Cell Analyzer and leveraging best-in-class electronics and fluidics technologies, the FP7000 sorter delivers the high resolution, sensitivity, and performance required for profiling and sorting heterogeneous populations, including rare cell phenotypes.

FP7000 Spectral Cell Sorter— Experience the Difference

Unparalleled System Design, featuring powerful optics, reliable fluidics technology for high-speed sorting, and robust unmixing algorithms, delivers the highest data quality and performance while eliminating subjective analysis (e.g., compensation) for spectral cell sorting.

- Configurable with up to 6 lasers and 182 detectors, to use multicolor panels of >44 colors.**
- Real-time spectral unmixing for high-speed sorting (25,000 eps at 100 kHz, using a 70- μ m nozzle).
- Streamlined software workflows with built-in troubleshooting and error handling ensure confidence in operation, even for new users.
- Automated system maintenance and remote service support provide peace of mind for laboratory administrators.

Support for a Wide Range of Applications has been a cornerstone of our system and software design philosophy. The FP7000 Spectral Cell Sorter is built with the flexibility to meet the diverse cell sorting needs of multi-user facilities, based on biological conditions and cell types being used.

- Multiple nozzle sizes are available to sort a range of cell types.
- A choice of default and custom sort modes for optimal sorting of a range of applications.
- A seamless nozzle setup and exchange process reduces downtime between users and/or experiments to increase laboratory efficiency, while delivering the highest data quality.
- Optics matched with the ID7000 Spectral Cell Analyzer to sort populations of interest without extensive panel redesign and optimization.
- Optional upgrades for specialized applications—405-nm SSC option for detection and sorting of small particles.

** Based on current testing and commonly available (non-custom) antibody fluorochrome conjugates



Nozzles—70 μm , 100 μm , and 130 μm —can be loaded on the **nozzle loader**.



Users can exchange the **sample line** as part of routine maintenance or based on their application needs.

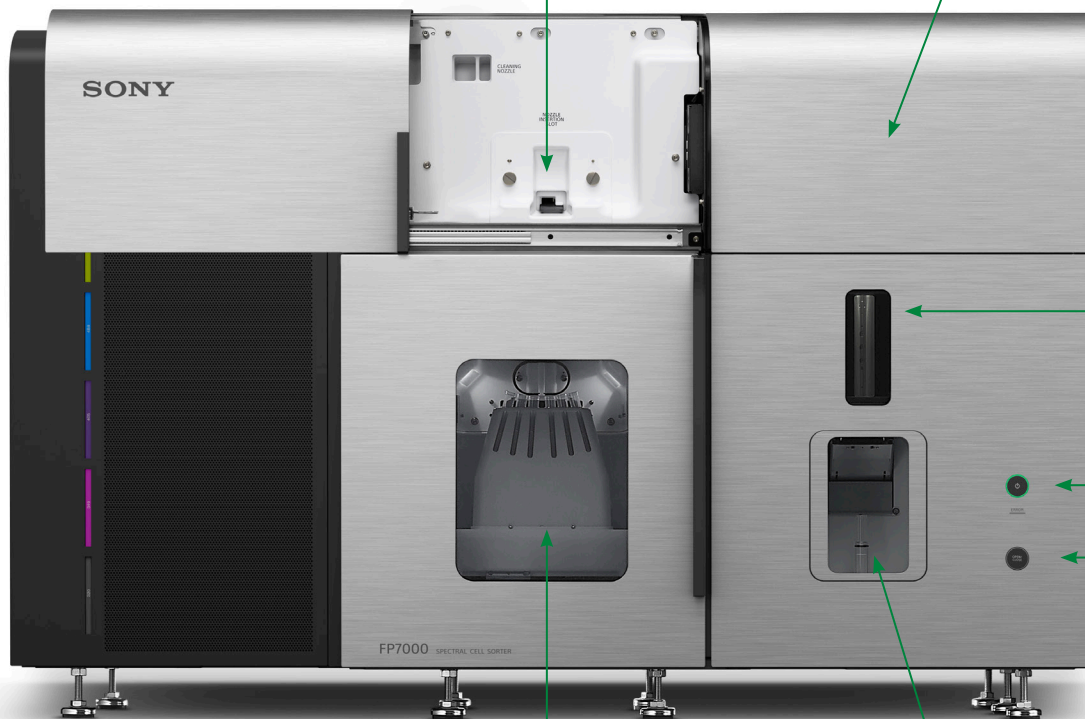

Samples can be agitated at 300 and 150 rpm using eccentric rotation.

Power button

Sample loader open/close button



Sort chamber supports 6-way, 4-way, and 2-way tube holders cooled using a Peltier device. Supports single-cell sorting into 96- and 384-well plates.



Tubes of various sizes (0.5 mL, 1 mL, 5 mL, and 15 mL) can be used in the **sample loader**, which maintains temperature at 5°C and 37°C using a built-in Peltier device.

Best-in-Class Resolution and Sensitivity to Address Evolving Research Needs

Researchers are using spectral flow cytometry for higher-level multiplexing than ever before, and a matched capability in cell sorting is needed to align with cell analysis. The FP7000 Spectral Cell Sorter was designed to deliver that capability, built on the foundation of the reliable, accessible workflows that are the hallmarks of the Sony flow cytometry portfolio.

The key determinant for success in high-complexity multicolor experiments is the quality of the optics design, which can lead to greater insights in the study of complex hierarchies and deep cellular phenotyping.

The core of the FP7000 Spectral Cell Sorter optics design is a quartz cuvette in fixed alignment with six spatially separated lasers, coupled to the fluorescence collection (emission optics) system consisting of a 32-channel photomultiplier tube (PMT) array per laser. Emitted light is collected from 360 nm to 860 nm using PMTs, and a spectral fingerprint is generated.

The robust collection system provides high resolution across the entire detector array for a larger, more evenly distributed detection range, and minimizes light loss. Researchers get maximum flexibility in the choice of fluorochromes and highest sensitivity and resolution for detection of subsets in multicolor samples—even when fluorochromes with overlapping emission spectra are used. A patented WLSM algorithm provides a robust and precise capability for unmixing fluorescence signals.

Performance Today and in the Future

Together, these technologies address the need for supporting increasingly complex panel designs in high-parameter applications. The system provides the resolution needed to unmix spectral signatures that have significant overlap, so users can select spectrally similar, closely spaced fluorochromes to get more from each experiment.

With the FP7000 Spectral Cell Sorter, researchers will therefore be able to choose from over 44 fluorochromes** for their high-parameter experiments, to confidently sort populations with complex hierarchical gating approaches with high purity.

- Choice of lasers includes blue (488 nm), red (637 nm), violet (405 nm), yellow-green (561 nm), ultraviolet (349 nm), and deep ultraviolet (320 nm). Each excitation laser has power specifications optimized to deliver the highest performance for detecting dim and rare markers.
- Detection of autofluorescence signal from any laser and assigning it as an independent parameter for sorting, or to unmix it from fluorescence signals, improves data quality.
- The small particle detection option enables light scattered from the 405-nm laser to be collected to detect submicron particles 100 nm in size, allowing researchers to sort them for a variety of downstream assays.

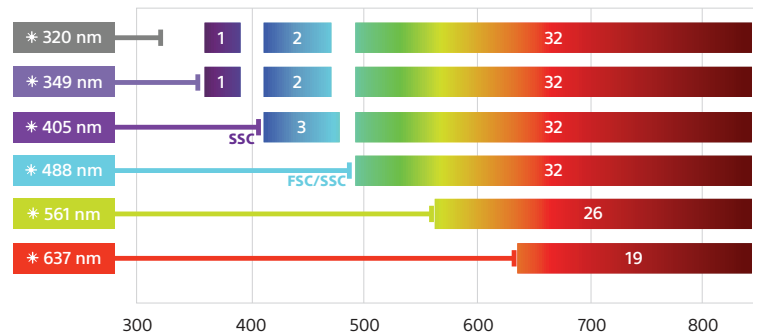

Figure 1 – FP7000 Spectral Cell Sorter optics for 6-laser configuration

** Based on current testing and commonly available (non-custom) antibody fluorochrome conjugates

Resolution of Highly Overlapping Fluorochromes

The detection optics of the FP7000 Spectral Cell Sorter evenly detects spectral signatures of fluorochromes with a resolution of approximately 10 nm across all 32-channel PMT arrays. Combinations of fluorochromes with highly overlapping spectra can therefore be easily resolved.

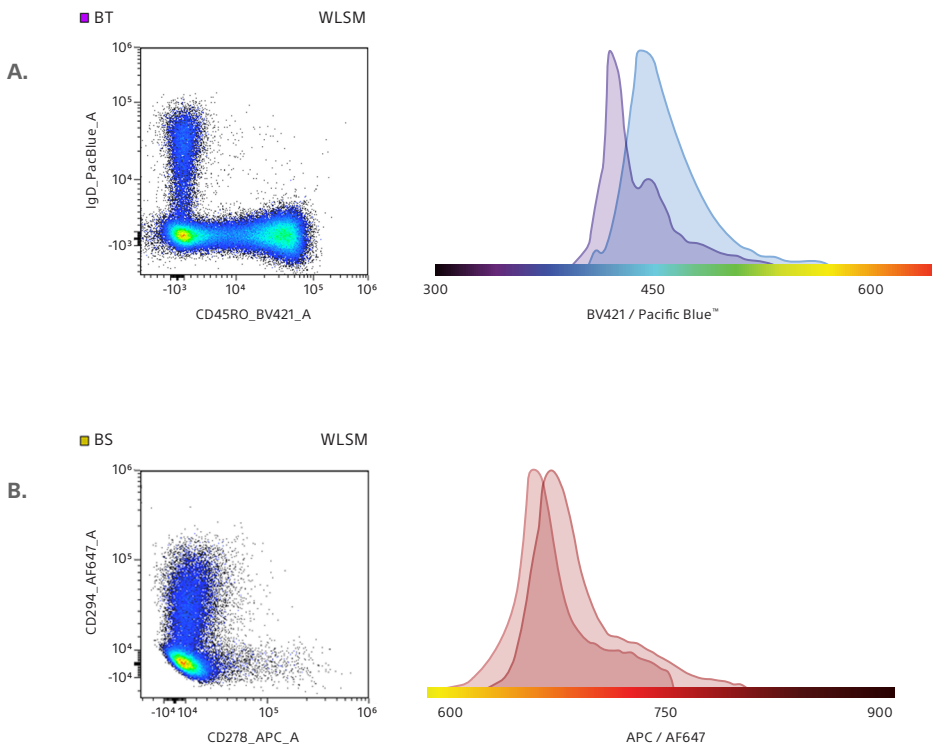

Figure 2 – Analysis of cells stained with overlapping fluorochromes

PBMCs were stained with 34 color T and B cell panel using fluorochromes with overlapping emission peaks. This sample was excited by the 488-nm, 405-nm, 561-nm, and 637-nm lasers and analyzed on the FP7000 Spectral Cell Sorter.

- A.** Populations stained with CD45RO-BV421 and IgD-Pacific Blue™ distinctly resolved in the 405-nm laser channels.
- B.** Populations stained with CD278-APC and CD294-Alexa Fluor® 647 were distinctly resolved in the 637-nm laser channels.

Next-generation Fluidics and Automated Setup Support a Range of Applications

The fluidics system of the FP7000 Spectral Cell Sorter is designed to deliver high uptime and reliable performance for seamless operation in laboratories performing a wide range of applications. The FP7000 system uses a quartz flow cell which is in fixed alignment with the lasers. Each laser is precisely focused on the core stream within the flow cell to generate the highest amount of fluorescence signal. The flow cell is gel coupled to the collection optics and low acceleration of the particles as they pass through the beam. This ensures that maximum light is collected to deliver the highest sensitivity and resolution, critical for high-parameter experiments.

Advanced Nozzle Design

The FP7000 features a new nozzle design to allow for smooth transitions between users and applications. The plastic nozzle precisely fits with the quartz flow cell and is located on the base plate for easy installation by any user. For optimal sort results for a given application, the appropriate nozzle size has to be used based on particle/cell size and fragility, and viability requirements.

- Users scan the QR code on the nozzle assembly to initiate automated startup. Each nozzle can be easily exchanged, supporting robust operation over the course of the day and seamless transition between users.
- The nozzle operates without an O-ring. This O-ring free design ensures that users do not have to perform tasks associated with a typical nozzle, including subjective adjustments, alignment, or installation of lost O-rings. In the event of a clog, the nozzle can be removed, sonicated, and reused.

Robust Fluidics

Sheath excitation technology ensures robust operation of different types of nozzles and forms stable droplets at a frequency range of 12 kHz to 100 kHz and at a pressure range of 70 kPa to 600 kPa, enabling stable, multiway sorting into tubes and single-cell sorting into plates. Thus, nozzles can be set up at optimal pressure levels, for example, 70 μm at ~ 100 KHz, 100 μm at ~ 30 KHz, and 130 μm at ~ 12 kHz.

- Six-way and 4-way sorting can be performed using the 70- μm and 100- μm nozzles, and the 130- μm nozzle can be used for 4-way and 2-way sorting.
- All nozzles can be used for sorting into 96- and 384-well plates.
- With each nozzle, users can select a default sort mode such as purity, normal, yield, or single cell, or create a custom sort mode to obtain superior sort results.
- Each nozzle can be easily exchanged for efficient operation over the course of the day and for seamless transition between users.



Base Plate

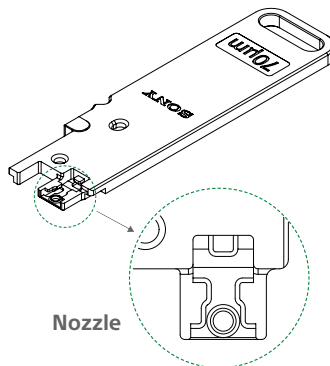

Nozzle



High-Efficiency Sorting of Single Cells and Index Cell Analysis

The FP7000 Spectral Cell Sorter features a best-in-class sort deposition system engineered for precise deposition of single cells into 96- and 384-well plates. The position of each plate relative to the stream is automatically adjusted to enable users to confidently set up their experiment. Several other features built into the system ensure accurate single-cell deposition for a broad range of cell sizes.

- Users can sort target cells into each well at high efficiency by precisely adjusting the position of the plate and assigning the center of the drop relative to the target cell position.
- Angled plate holders for 96/ 384-well plates and specialized holders for V-bottom PCR plates available as accessories allow users to accurately sort into micro volumes of media or buffer per well.
- The index analysis feature in the software records the X and Y coordinates of each event sorted into a multi-well device, enabling users to track the scatter and fluorescence intensity of individual cells sorted in each well.

This indexed information for sorted cells, such as GFP fluorescence and scatter, can be used for correlating the phenotype of sorted cells and annotating it with clonal survival, gene expression, or functional assays.

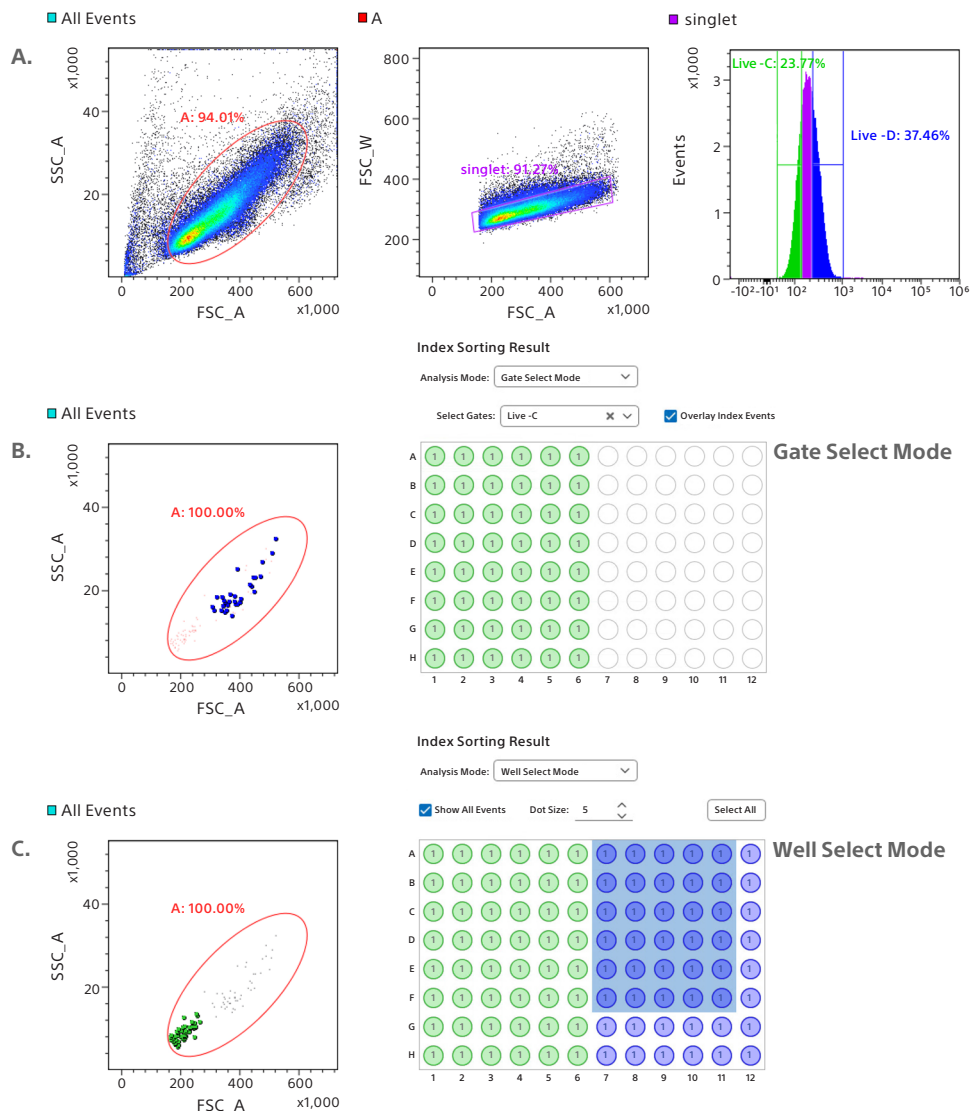

Figure 3 – Sorting of Jurkat cells using a 70-µm nozzle

- Jurkat cells stained with the viability dye DAPI were gated on scatter and singlets. Live cells were sorted into a 96-well plate using the single-cell mode.
- The index analysis feature was then used to determine the plate location of the cells using the Gate Select Mode.
- The Well Select Mode was used to identify the phenotype of the cells located within a well containing a sorted cell.

Sort Confidently with Guided Software Workflows

The FP7000 Spectral Cell Sorter software incorporates guided workflows and intuitive tools that enable researchers to generate high-quality unbiased data and superior sort results while completing tasks in a timely manner. The streamlined setup of experiments makes the system easy to use for researchers by creating a unified approach for repetitive tasks, reducing time to results.

Experiment Designer allows users to create a new experiment using new or pre-existing spectral references. The spectral references specify the unmixing that is applied to the multicolor sample. The Spectral Reference Library removes the need for single-color controls to be acquired for every new experiment. Experiments can be created using a previous template or new template depending on the experiment needs. The experiment workspace displays plots, gates, and statistics required for setup of an experiment. Stream monitoring capability such as sort stream and side stream camera views are displayed.

The Experiment tab

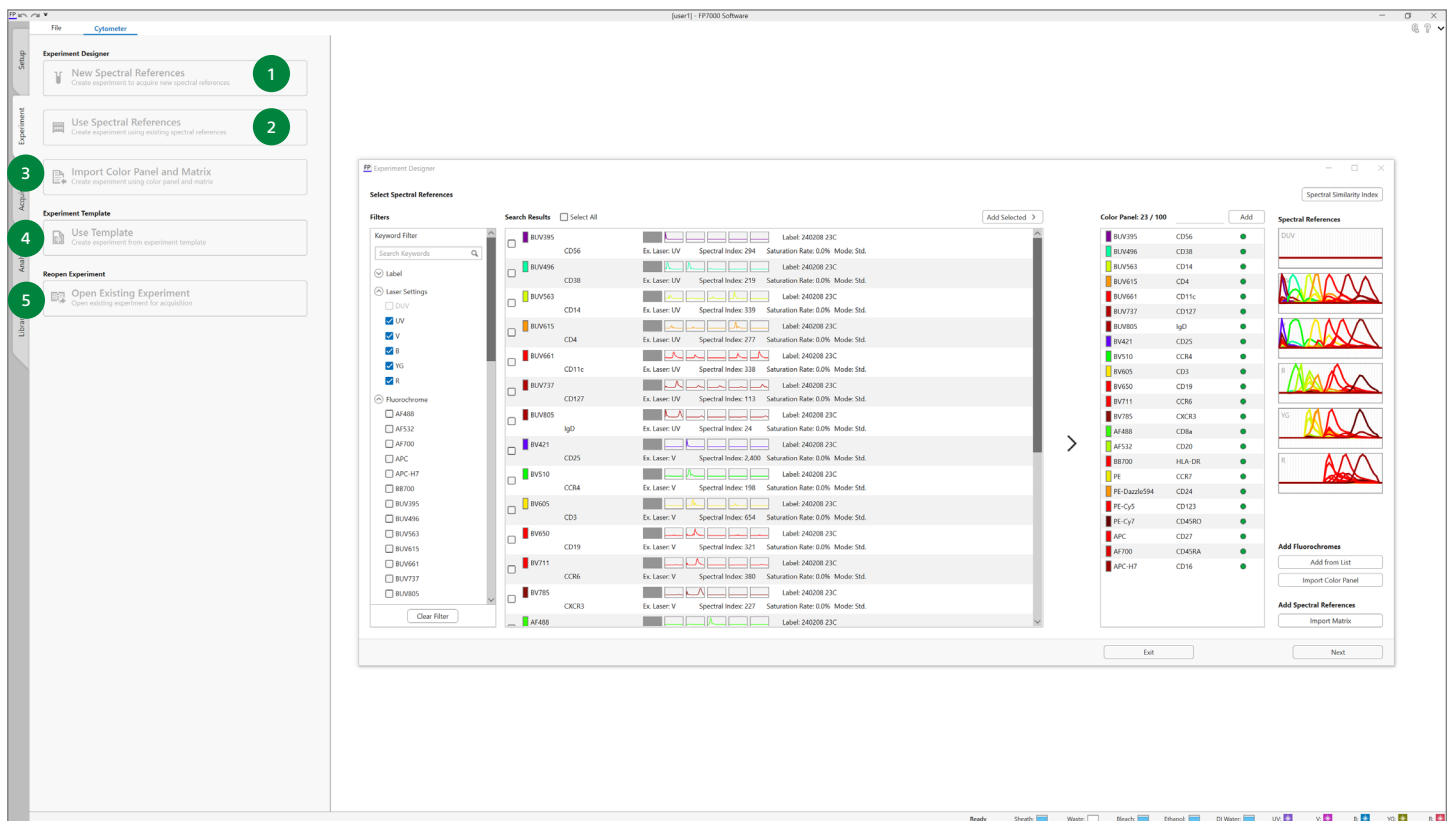

The **Experiment** tab includes tools required for setup of an experiment:

1. **New Spectral References** – create new spectral references for an experiment.
2. **Use Spectral References** – create experiment using existing spectral references.
3. **Import Color Panel and Matrix** – create spectral references using the color panel and matrix saved previously.
4. **Use Template** – create new experiment from existing template.
5. **Open Existing Experiment** – open existing experiment for acquisition.

The **Acquisition** tab includes tools required for data acquisition and sorting.

6. **Acquisition dashboard** displays acquired, and recorded event count, stopping condition, and event rate and sample pressure adjustment settings.
7. **Experiment Pane** displays available experiments/templates and the organization structure of the experiment.
8. **Workspace** for creating plots, gates, and statistics.
9. **Tools/Options** on ribbon menu related to data acquisition and sorting.
10. **Sorting dashboard** displays sorting statistics and sort controls, camera view of the side streams and droplets.

The data acquisition dashboard provides access to software options where users can specify flow rate, recording conditions, and stop count. The sorting dashboard provides options such as choice of sorting devices, sort modes, and stop count for each stream of a multi-way sorting experiment. The types of default sort modes available in the software are shown in Table 1. Tools for creating plate templates and adjusting plate coordinates can also be viewed here. Stream monitoring capabilities such as sort stream and side stream camera views are displayed.

The Acquisition tab

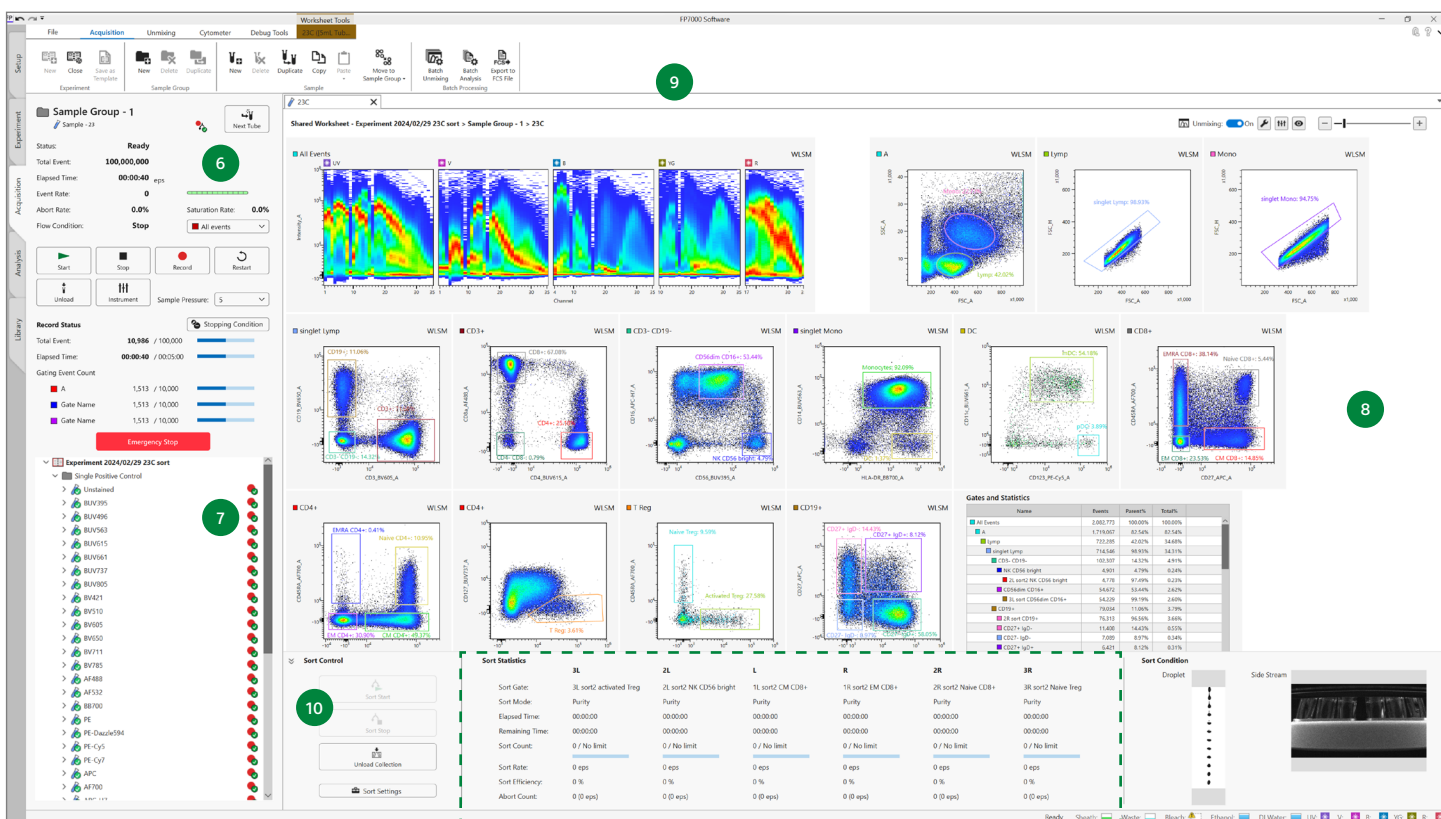

Figure 4 – Sort Statistics view includes Sort Gate, Sort Mode, Sort Count, Sort Rate, Sort Efficiency, and Abort Count

These parameters are updated in real time and can be viewed to monitor the progress of sorting.

	Sort Modes						
	Normal	Purity	Ultra-purity	Semi-purity	Yield	Semi-yield	Single Cell
Purity	++++	+++++	+++++	++++	+++	+++	++++
Yield	++++	++	+	+++	+++++	+++++	

Table 1 – Sort modes available in the FP7000 Spectral Cell Sorter software

+ indicates the relative outcome of purity or yield for a given sort mode.

Six-way, High-Speed Sorting of a High-Parameter Panel

The FP7000 Spectral Cell Sorter is built with advanced optics, fluidics, and electronics systems. A patented unmixing algorithm delivers real-time unmixing at high speed and with accuracy to resolve closely spaced fluorochromes and sort high-parameter samples at high speed. To highlight these capabilities of the FP7000 Spectral Cell Sorter, we used a 23-color immunophenotyping panel of T-, B-, and NK-cell subsets for high-speed sorting of rare and dim target populations. Six populations – CD19+CD3- B cells, CD14+ monocytes, CD56+CD16- NK cells, CD4+CD8- T cells, CD4-CD8+ T cells, and CD4-CD8- T cells—were identified. These populations were sorted six ways with the Purity sort mode in the software and using the 70- μ m nozzle set up at 100 kHz. Each tube was then analyzed post-sort to assess the purity of each population.

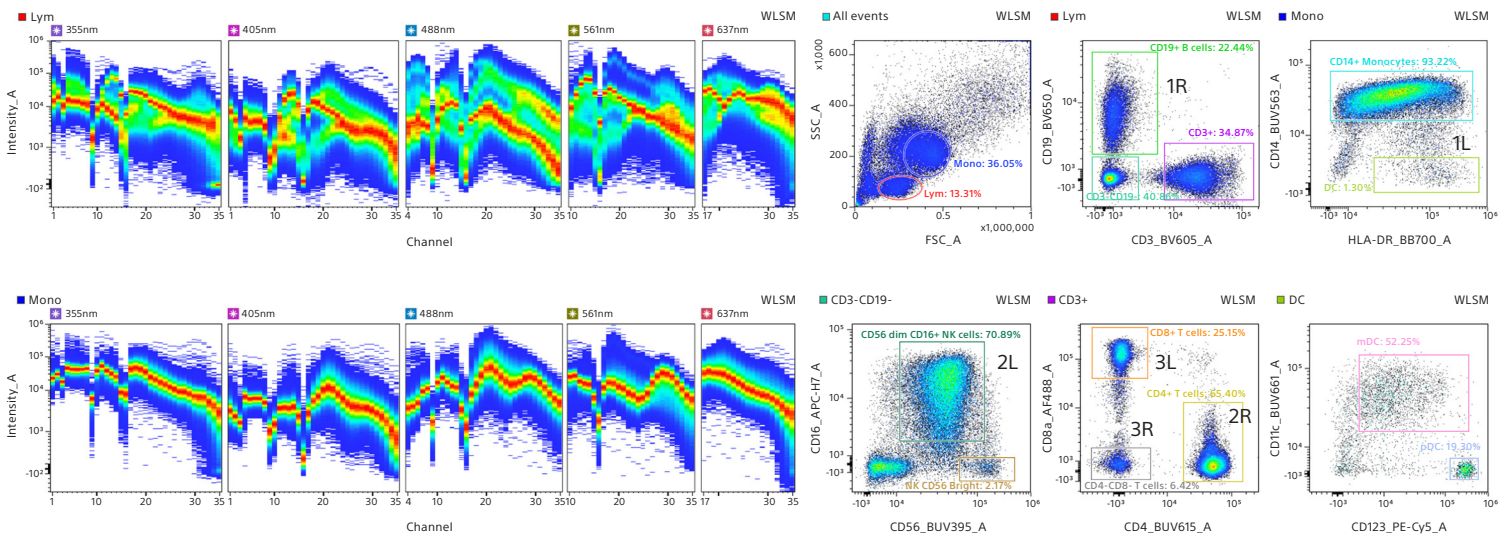

Figure 5A – High speed sorting of a 23-color panel using the FP7000 Spectral Cell Sorter

PBMCs (12×10^6 cells/mL) were stained with a 23-color panel using the reagents shown in Table 2 and run at 17,000 eps on the FP7000 Spectral Cell Sorter set up with the 70- μ m nozzle at 100 kHz. Using the hierarchical gating scheme shown in the bivariate plots, six target populations—CD19+CD3- B cells (1R tube), CD14+ monocytes (1L tube), CD56+CD16- NK cells (2L tube), CD4+CD8- T cells (2L tube), CD4-CD8+ (3L tube), CD4-CD8- T cells (3R tube)—were sorted into 6-way tubes using Purity mode.

Fluorochrome	Marker
BUV395	CD56
BUV496	CD38
BUV563	CD14
BUV615	CD4
BUV661	CD11c
BUV737	CD127
BUV805	IgD
BV421	CD25
BV510	CD194
BV605	CD3
BV650	CD19
BV711	CD196
BV785	CD183
AF488	CD8a
AF532	CD20
PE	CD197
PE-Dazzle594	CD24
PE-Cy5	CD123
BB700	HLA-DR
PE-Cy7	CD45RO
APC	CD27
AF700	CD45RA
APC-H7	CD16

Table 2 – Markers and fluorochromes used in 23-color TBNK panel

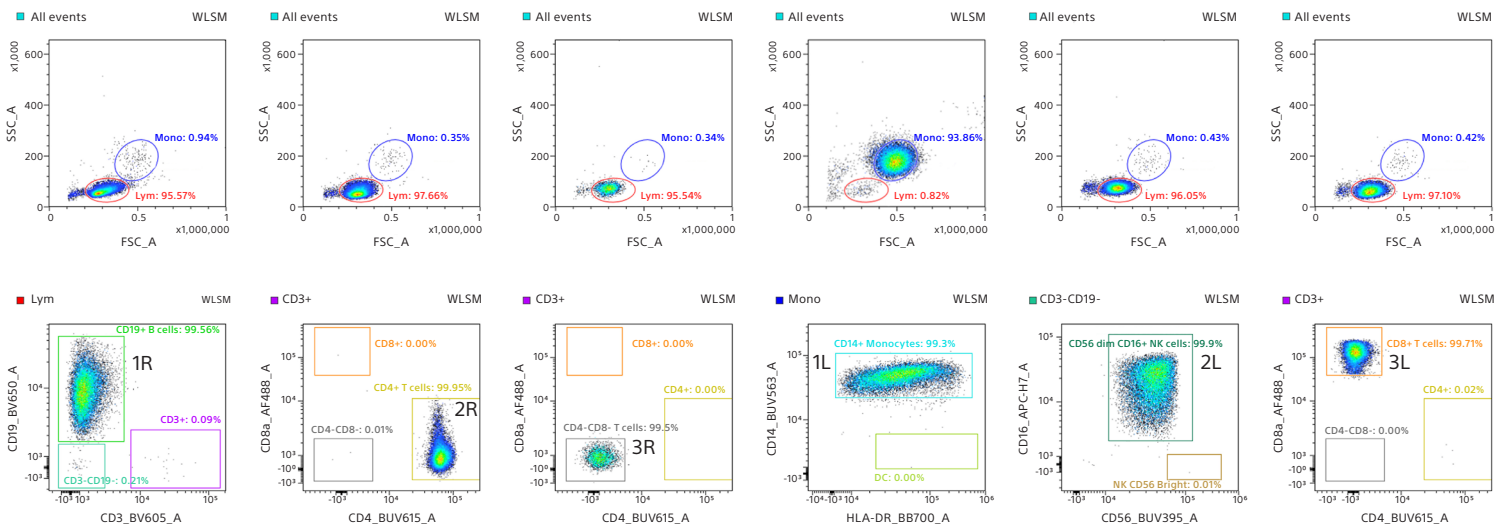

Figure 5B – Post-sorting purity check of a 23-color panel

Cell sorted from the 23-color panel were analyzed post-sort to evaluate the purity. Post-sort analysis demonstrated >99% purity of each sorted population.

	3L	2L	1L	1R	2R	3R
Purity	99.71%	99.9%	99.9%	99.56%	99.95%	99.5%

Table 3 – Sort purity for 6-way sorting

Seamless Compatibility Accelerates Discoveries

With matched configurations between the ID7000 Spectral Cell Analyzer and FP7000 Spectral Cell Sorter, researchers can obtain high-quality results data from both systems. They can easily develop a high-parameter panel on the ID7000 Spectral Cell Analyzer using a new or previously created template, and set up the plots and the gating strategy to analyze the different cell subsets in the high-parameter panel. Once the cellular phenotypes of interest are identified, the experiment template and the optimized panel can be transferred to the FP7000 Spectral Cell Sorter, where the cell subsets of interest are resolved with the same level of accuracy and can be sorted for downstream cell assays for driving discovery research.

This seamless compatibility between the ID7000 Spectral Cell Analyzer and the FP7000 Spectral Cell Sorter enables users to save on time required to set up, optimize, and validate an experiment for sorting. This increases the workflow efficiency and shortens the time to result and reduces the use of reagents.

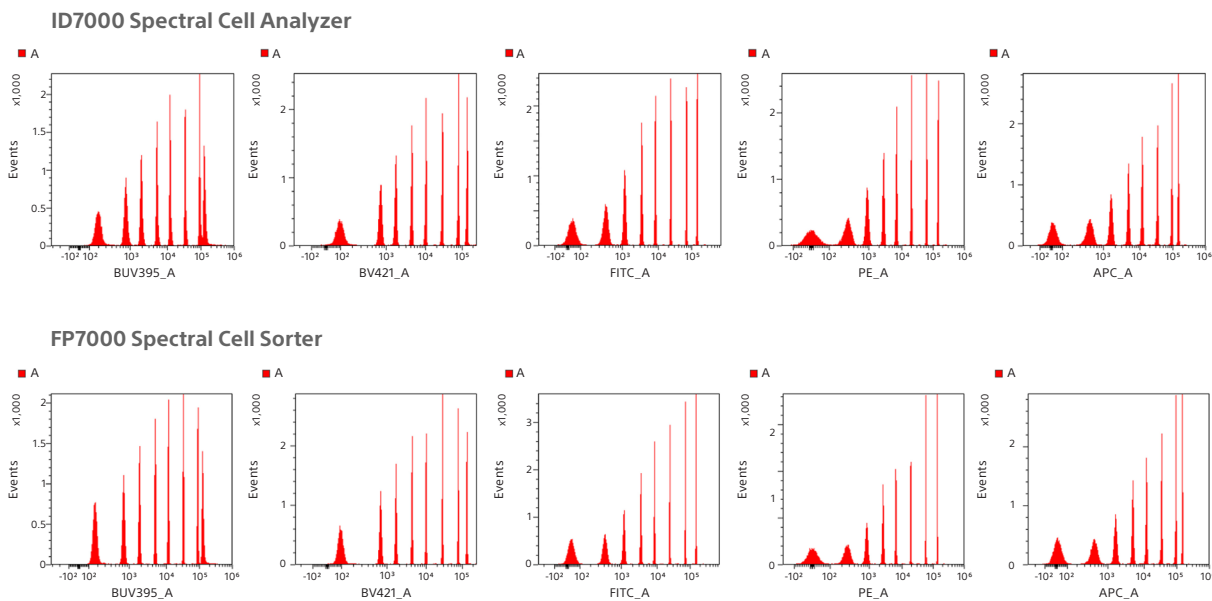
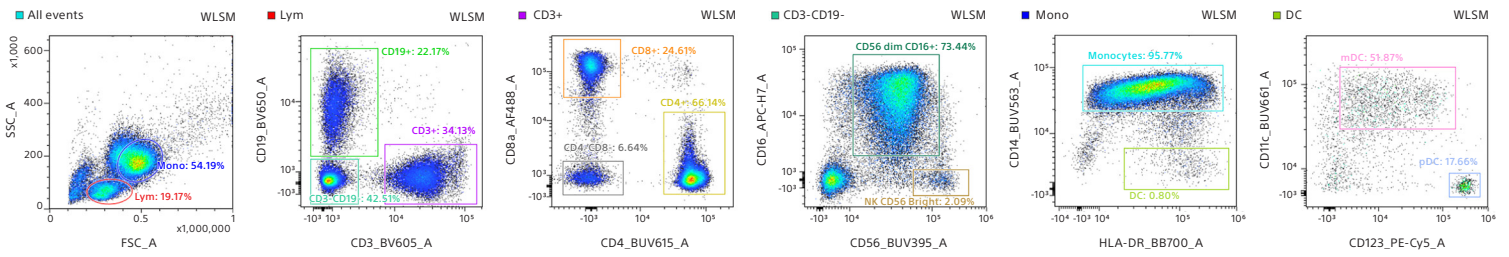

Figure 6 – Comparison of optical performance of the 5-laser configuration of ID7000 Spectral Cell Analyzer and FP7000 Spectral Cell Sorter using 8 peak beads



ID7000 Spectral Cell Analyzer



FP7000 Spectral Cell Sorter

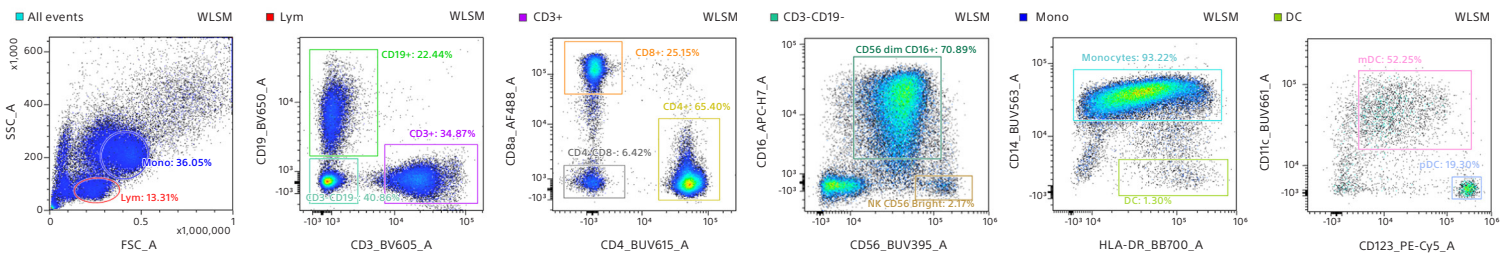

Figure 7 – Optical performance for multi-color panel portability using the ID7000 Spectral Cell Analyzer and FP7000 Spectral Cell Sorter

Frozen PBMCs were thawed and stained with a 23-color panel using reagents shown in Table 2. The ID7000 Spectral Cell Analyzer and FP7000 Spectral Cell Sorter, each equipped with five lasers (UV, violet, blue, yellow-green and red lasers) were set up using Standardization mode. Single stained compensation beads were run to create a reference library, and the multicolor sample of PBMCs (10 million/mL) was analyzed on both instruments. The results show comparable resolution and sensitivity between the two instruments.

Seamless Compatibility Accelerates Discoveries

Unsupervised analysis of the data from the ID7000 Spectral Cell Analyzer and the FP7000 Spectral Cell Sorter using dimensionality reduction algorithms show that both systems generate similar high-quality data and resolve the same populations with similar degree of accuracy.

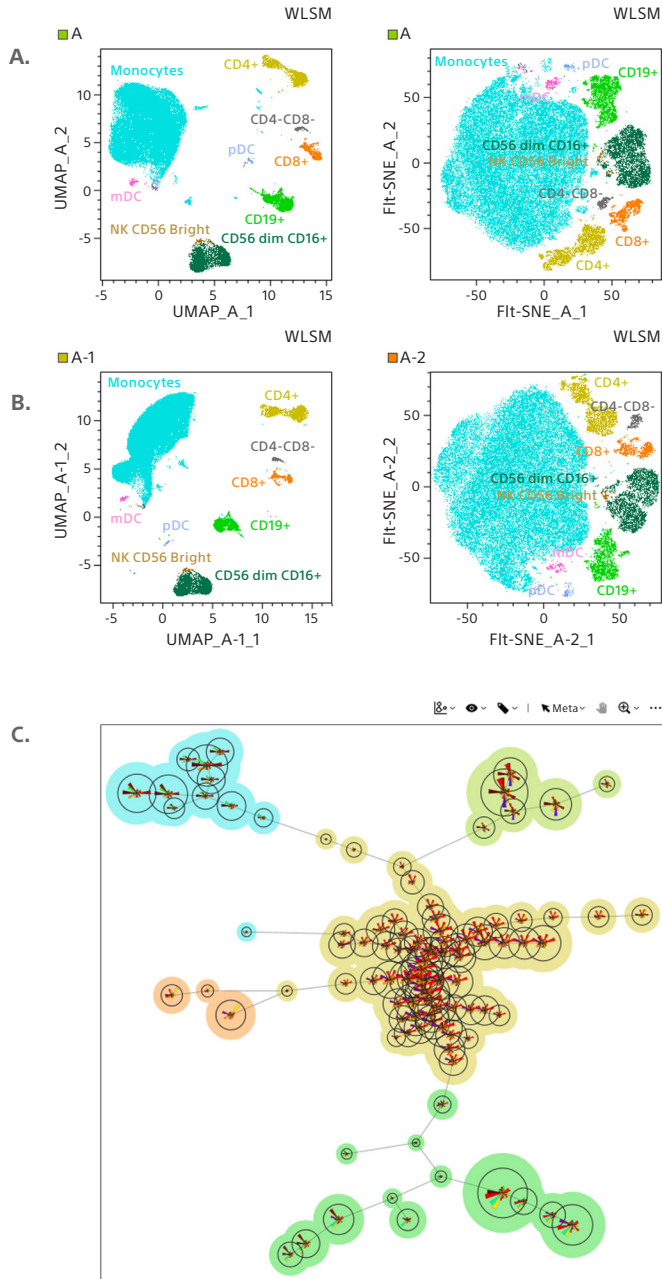

Figure 8 – Unsupervised analysis of 23-color TBNK panel data

The results of the 23-color panel analysis and raw data were imported into the Spectral Flow Analysis (SFA) software. Singlet lymphocytes were gated to generate 2D plots.

- A.** Dimensionality reduction plots of the data from the ID7000 Spectral Cell Analyzer using UMAP and Fit-SNE.
- B.** Dimensionality reduction plots of the data from the FP7000 Spectral Cell Sorter using UMAP and Fit-SNE.
- C.** Cluster analysis of the data from FP7000 Spectral Cell Sorter using BL-FlowSOM.
- D.** Star chart and heat map of cluster analysis displaying percentage of each population and the intensity of fluorochrome.

Ease of Ownership for Multi-user Laboratories

Automated Maintenance and Troubleshooting

High system uptime and robust system setup that ensures optimal performance throughout the day are of utmost importance for seamless operation in multi-user laboratories. The FP7000 Spectral Cell Sorter is designed with a comprehensive fluidics cart that houses autoclavable sheath, deionized water, and waste tanks, as well as bleach and ethanol tanks.

- Weight sensors on the fluidics cart allow a real-time measurement of fluid levels in each of the five tanks, which is displayed in the software.
- Guided software workflows enable a user to perform routine maintenance and cleaning procedures and troubleshoot the system.
- Based on the needs of the applications, the administrator can choose to prepare for aseptic sort using either ethanol or bleach and customize the length of the cleaning cycle.
- Administrators can set up custom cleaning and maintenance schedules in the software. This generates automated reminders on a weekly or monthly basis to prompt operators to perform a maintenance task.

Biosafety Solution

The FP7000 Spectral Cell Sorter can be installed inside a custom class A2 level II biosafety cabinet (BSC) that provides product, personnel, and environmental protection.

It meets international standards including the National Sanitation Foundation Standard 49 (NSF49) and the European Standard 12469. This cabinet is equipped with a built-in aerosol management system, operating independently of the BSC to actively evacuate aerosols from the sort chamber, providing a redundant mechanism for aerosol evacuation to maximize personnel protection.



Figure 9 – FP7000 Spectral Cell Sorter inside custom class A2 level II Biosafety Cabinet

Your Partner in Service and Support

Sony Biotechnology is dedicated to offering our customers the highest quality instruments supported by a best-in-class service and support team. The FP7000 Spectral Cell Sorter is designed to enable researchers to seamlessly pursue high-parameter flow cytometry with confidence. We are committed to maximizing instrument uptime by providing you phone, in-person, and remote diagnostics and troubleshooting services.

Technical Support

Our knowledgeable and experienced application scientist team is available for local support to help you get the most out of your FP7000 Spectral Cell Sorter by providing you with instrument and training and application support.

Field Service

Our trained field service engineers provide in-person instrument services and can also diagnose and troubleshoot system health remotely. We offer comprehensive service plan packages to support all budgets. In addition to the standard service agreement which includes comprehensive technical service and support, diagnostics, and repair as well as preventive maintenance, we also offer instrument qualification through IQ and OQ service.

637

561

488

405

North America/International

1730 North First Street
San Jose, CA 95112 U.S.A.
Tel: +1 800-275-5963
Fax: +1 408-352-4130
sales@sonybiotechnology.com
www.sonybiotechnology.com

Japan

5-1-1, Minato Mirai, Nishi-ku,
Yokohama-shi, Kanagawa,
220-8750 Japan
Tel: +81 120-677-010
Fax: +81 120-388-060
sales_Japan@sonybiotechnology.com
www.sony.co.jp/LS

China

301,3/F, Commercial Podium,
Ping An International Financial Center
No. 1 South Xinyuan Road,
Chao Yang District
Beijing 100027, P.R. China
Tel: +86 400 619 7910
fcm@sony.com.cn

Europe

The Heights, Brooklands.
Weybridge, Surrey,
KT13 0XW, UK
SESSalesSupport@sony.com